

REV.	ECN.NO.	APPD.
A	EXXXXXXXXXX	yangguifeng

NOTES:
SPECIFICATION:

1. CURRENT RATING: 3.0A MAX
2. DIELECTRIC WITHSTAND VOLTAGE: 100VAC
3. TEMPERATURE RANGE: -30 °C ~ 85 °C
4. CONTACT RESISTANCE: 40 MILLIONHM MAX
5. INSULATION RESISTANCE: 100 MEGOHMS MIN.
6. INSERTION FORCE : 5N~20N
7. UNMATING FORCE: 8N~20N
8. DURABILITY:5000 CYCLES

F
E
D
C
B
A

F
E
D
C
B
A

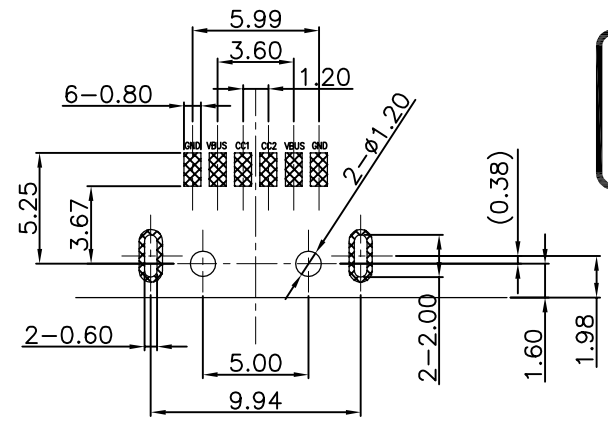
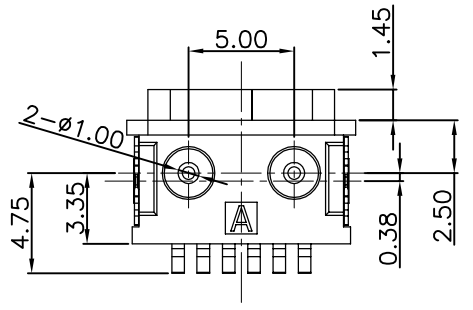
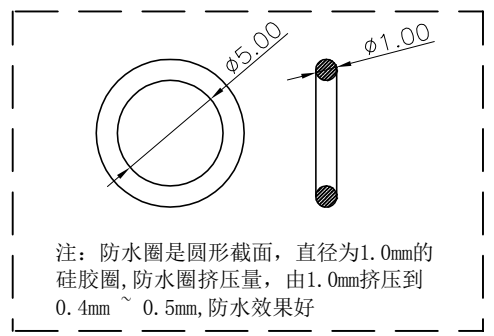
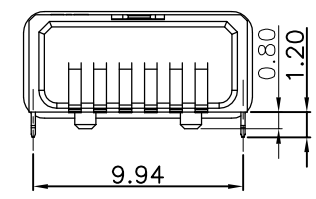
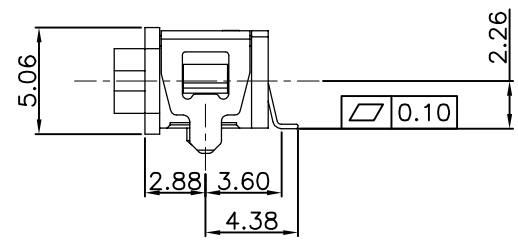
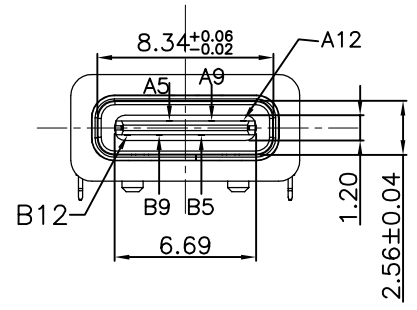
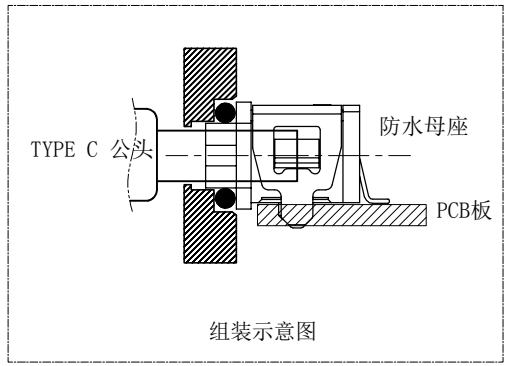
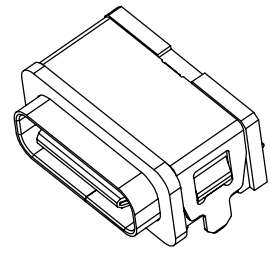
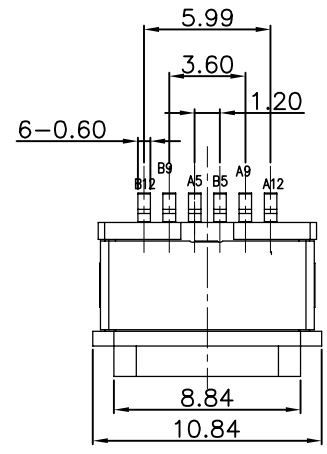

U572-951X-XXX0X8

- | | | | |
|----------|------------|--|-----------|
| 1: 铁壳镀镍 | 1: 半金1u" | | |
| 5: 铜壳镀镍 | 3: 半金3u" | | |
| B: 不锈钢镀镍 | 5: 半金5u" | | |
| | G: 半金G/Fu" | | |
| | 9: 镀全金1u" | | |
| | 2: 镀锡 | | |
| | 1: PA66 | | 1: 吸塑盒 |
| | | | 2: 吸塑管 |
| | | | 3: 载带 |
| | | | 6: 载带+贴麦拉 |
| | 2: PBT | | 1: 黑色 |
| | 5: PA9T | | 2: 白色 |
| | | | 3: 米黄色 |

RECOMMENDED PCB LAYOUT(TOP VIEW)

THICKNESS T=1.0mm
DEFAULT TOLERANCE+/-0.05

A5	CC1	B12	GND
A9	VBUS	B9	VBUS
A12	GND	B5	CC2
PIN	SIGNAL NAME	PIN	SIGNAL NAME

TOLERANCE UNLESS OTHERWISE SPECIFIED		FLW 深圳市华联威电子科技有限公司			
.XXX ±0.10 .XX ±0.20 .X ±0.30		HUA LIAN WEI TECHNOLOGY ELECTRONICS CO.;LTD.			
APPROVED		PART NAME:	TYPE C 6P SMT两脚有柱1.0		
CHECKED		PART No:	U572-951B-G51038	C	
DRAWN	yangguifeng	PROJECTION:	UNIT:	SCALE:	SHEET
DATE	2021.12.01		mm	1:1	1 OF 1
					REV. A