

REV.	ECN.NO.	APPD.
B	修改尺寸标注	ZFY
C	依实物修改公差	chenyiting

NOTES:

1.MATERIAL:

1.1 Housing:thermoplastic plastics

1.2 terminals:Copper Alloy

Gold plated in contact area:

Tin plated in termination

Nickel Plated overall

1.3 Shell:Steel&Copper Alloy

Nickel Plated overall

2.ELECTRICAL CHARACTERISTICS:

2.1 Rating Current :1.5 Ampere

2.2 Rating Voltage :30 V Max

2.3 Contact Resistance:30 Milli ohms

2.4 Insulation Resistance:1000 Mega ohms Min.

3.MECHANICAL CHARACTERISTICS:

3.1 Connector Mating force: 35N MAX(3.57KgF)

3.2 Connector Unmating force:10N min(1.02KgF)

3.3 Durability:1500Cycles.

4.ENVIRONMENT CHARACTERISTICS:

4.1 Operating temperature:-0°C to +50°C

4.2 Storage temperature:-20°C to +60°C

U221-7015-G22017

5:铜壳镀镍

G:半金G/Fu"

1:吸塑盒

2:白色

2:PBT

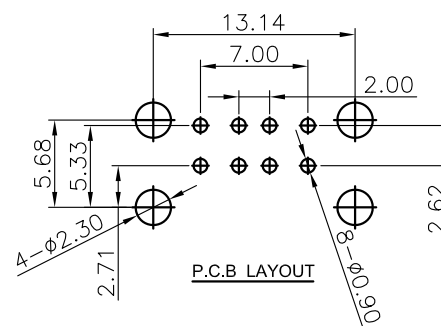
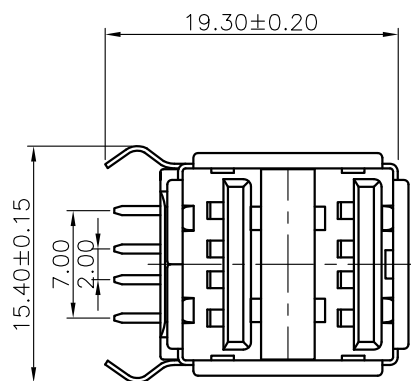
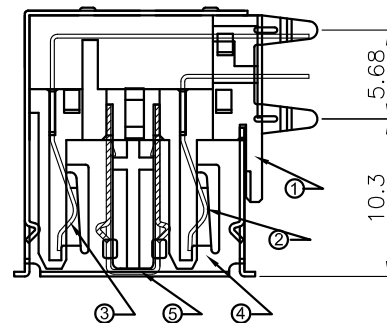
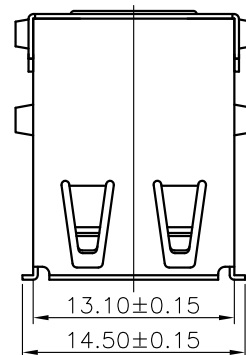
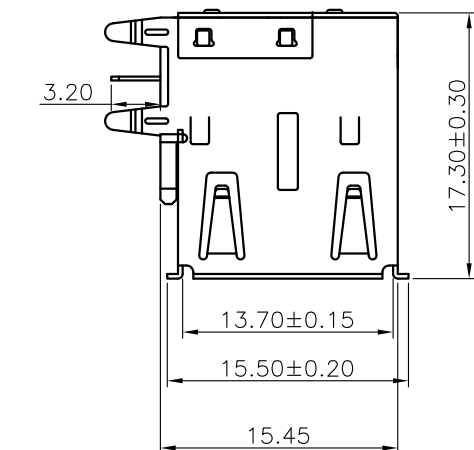

TOLERANCE UNLESS OTHERWISE SPECIFIED		FLW 深圳市华联威电子科技有限公司				
.XXX ±0.15	.XX ±0.25	.X ±3'	HUA LIAN WEI TECHNOLOGY ELECTRONICS CO;LTD.			
.X ±0.30	.XX' ±2'					
APPROVED		PART NAME:	USB AF 90度 双层半包无弹外壳连体			
CHECKED		PART No:	U221-7015-G22017	C		
DRAWN	chenyiting	PROJECTION:	UNIT:	SCALE	SHEET	REV.
DATE	2022.07.19		mm	1:1	10F1	C