

REV.	ECN.NO.	APPD.
A	EXXXXXXXXXX	yangguifeng

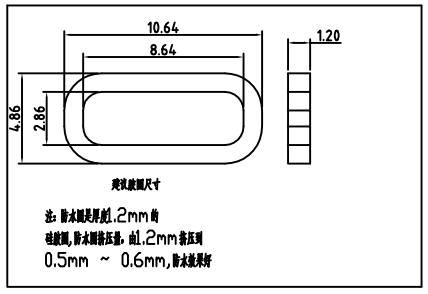

- NOTES:
SPECIFICATION:
- CURRENT RATING: 3.0A MAX
 - DIELECTRIC WITHSTAND VOLTAGE: 100VAC
 - TEMPERATURE RANGE: -30 °C ~ 85 °C
 - CONTACT RESISTANCE: 40 MILLIONHM MAX
 - INSULATION RESISTANCE: 100 MEGOHMS MIN.
 - INSERTION FORCE : 5N~20N
 - UNMATING FORCE: 8N~20N
 - DURABILITY:10,000 CYCLES

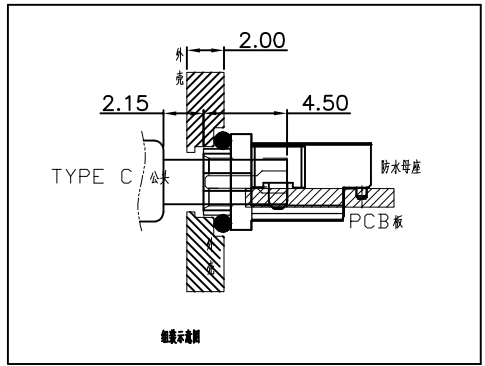
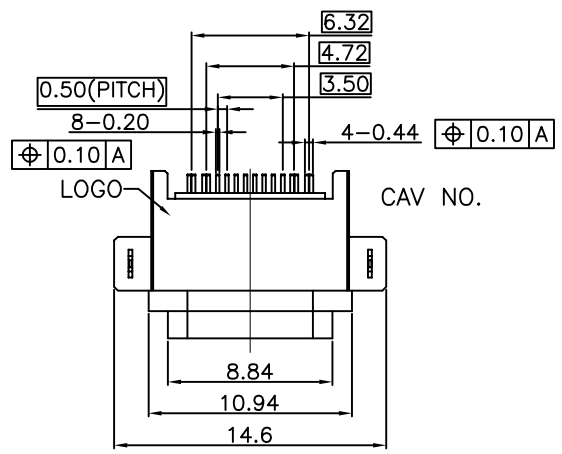
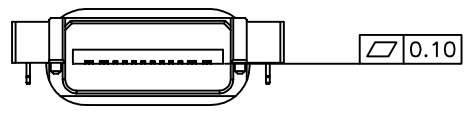
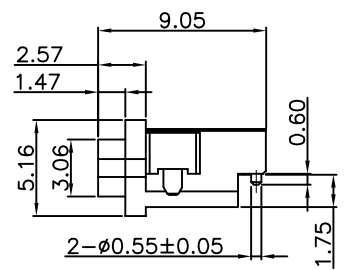
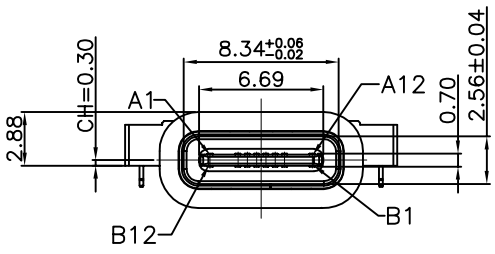

- U572-911X-XXXXX8
- 1: 铁壳镀镍
 - 5: 铜壳镀镍
 - B: 不锈钢镀镍
 - 1: 半金1u"
 - 3: 半金3u"
 - 5: 半金5u"
 - G: 半金G/Fu"
 - 9: 镀全金1u"
 - 2: 镀锡
 - 1: PA66
 - 2: PBT
 - 5: PA9T
 - 1: 吸塑盒
 - 2: 吸塑管
 - 3: 载带
 - 6: 载带+贴麦拉
 - 1: 黑色
 - 2: 白色
 - 3: 米黄色

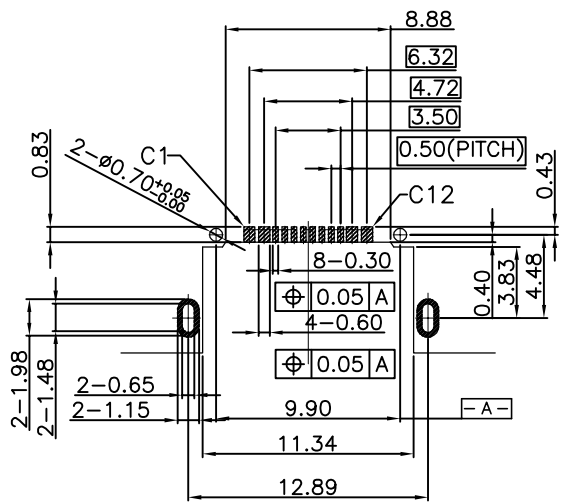
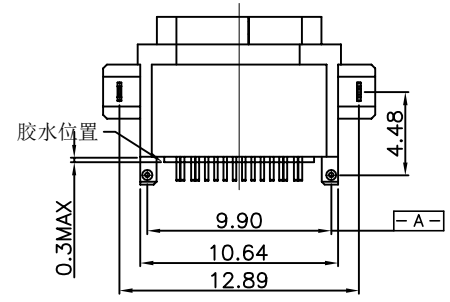

INTERFACE(FRONT VIEW)

A1	A2	A3	A4	A5	A6	A7	A8	A9	A10	A11	A12
GND		VBUS	CC1	DP1	DN1	SBU1	VBUS				GND
GND		VBUS	SBU2	DN2	DP2	CC2	VBUS				GND
B12	B11	B10	B9	B8	B7	B6	B5	B4	B3	B2	B1

PIN ASSIGNMENT

PIN NO.	A1&B12	A4&B9	B8	A5	B7	A6	A7	B6	A8	B5	A9&B4	A12&B1
SIGNAL NAME	GND	VBUS	SBU2	CC1	DN2	DP1	DN1	DP2	SBU1	CC2	VBUS	GND
PCB PAD NO.	C1	C2	C3	C4	C5	C6	C7	C8	C9	C10	C11	C12

RECOMMENDED PCB LAYOUT(TOP VIEW)
THICKNESS T=1.0mm
DEFAULT TOLERANCE+/-0.05

TOLERANCE UNLESS OTHERWISE SPECIFIED		FLW 深圳市华联威电子科技有限公司			
.XXX ±0.10 .XX ±0.20 .X ±0.30		.X' ±3' .XX' ±2'		HUA LIAN WEI TECHNOLOGY ELECTRONICS CO;LTD.	
APPROVED		PART NAME:	TYPE C 16P SMT两脚有柱		
CHECKED		PART No:	U572-911B-G51038	C	
DRAWN	yangguifeng	PROJECTION:	UNIT:	SCALE	SHEET
DATE	2021.12.01		mm	1:1	1 OF 1
					REV. A