

REV.	ECN.NO.	APPD.
A	XXXXXXXXXX	yangguifeng

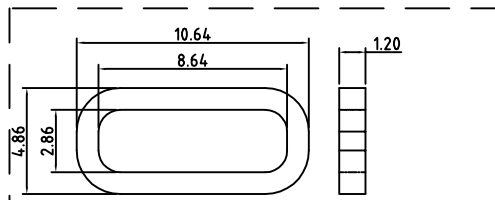

建议胶圈尺寸
注: 防水圈是厚度1.2mm的
硅胶圈, 防水圈挤压力, 由1.2mm挤压到
0.7mm ~ 0.8mm, 防水效果好

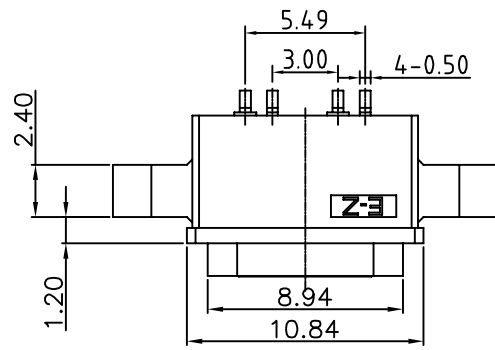
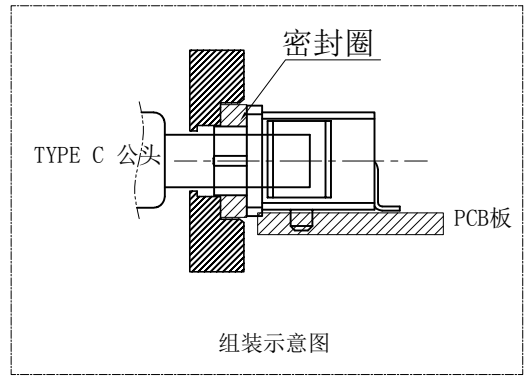

NOTES:

SPECIFICATION:

- CURRENT RATING: 3.0A MAX
- DIELECTRIC WITHSTAND VOLTAGE: 100VAC
- TEMPERATURE RANGE: -30 °C ~ 85 °C
- CONTACT RESISTANCE: 40 MILLIONHM MAX
- INSULATION RESISTANCE: 100 MEGOHMS MIN.
- INSERTION FORCE : 5N~20N
- UNMATING FORCE: 8N~20N
- DURABILITY:5000 CYCLES

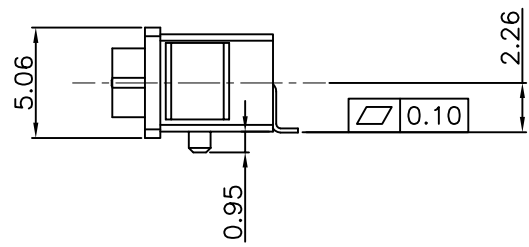
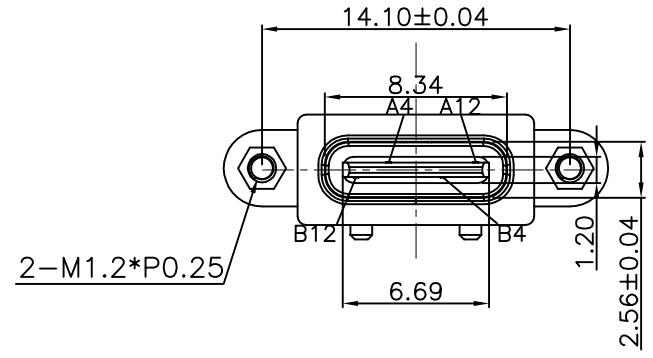

U572-A54X-XXX0X8

- 1: 铁壳镀镍
- 5: 铜壳镀镍
- B: 不锈钢镀镍
- 1: 半金1u"
- 3: 半金3u"
- 5: 半金5u"
- G: 半金G/Fu"
- 9: 镀全金1u"
- 2: 镀锡
- 1: PA66
- 2: PBT
- 6: LCP
- 1: 吸塑盒
- 2: 吸塑管
- 3: 载带
- 6: 载带+贴麦拉
- 1: 黑色
- 2: 白色
- 3: 米黄色

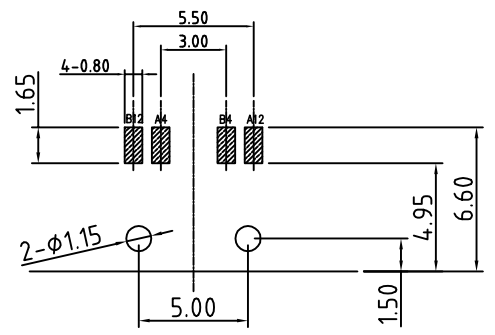
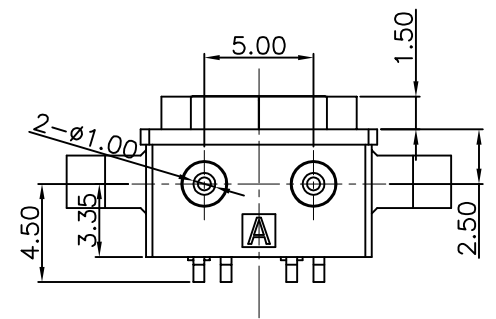

RECOMMENDED PCB LAYOUT(TOP VIEW)

THICKNESS T=1.0mm
DEFAULT TOLERANCE+/-0.05

A4	VBUS	B12	GND
A12	GND	B4	VBUS
PIN	SIGNAL NAME	PIN	SIGNAL NAME

TOLERANCE UNLESS OTHERWISE SPECIFIED		FLW 深圳市华联威电子科技有限公司			
.XXX ±0.10 .XX ±0.20 .X ±0.30		HUA LIAN WEI TECHNOLOGY ELECTRONICS CO.;LTD.			
APPROVED		PART NAME:	TYPE C 4P SMT带螺母有柱1.0		
CHECKED		PART No:	U572-A54B-G61038	C	
DRAWN	yangguifeng	PROJECTION:	UNIT:	SCALE:	SHEET:
DATE	2021.12.01		mm	1:1	1 OF 1
					REV. A