

REV.	ECH. NO.	APPD.
A	/	/

NOTES:
1. MATERIAL:
MOLDING: LCP UL94 V-0
CONTACT: COPPER ALLOY.
GOLD PLATED Min ON CONTACT AREA, 100u"
Min TIN (LEAD FREE) ON SOLDER AREA,
SHELL: SUS304-H,T=0.30±0.03mm
50u" NICKEL PLATING OVER ALL.

2. MECHANICAL:
INSERTION: 5~20N.
EXTRACTION: 8~20N AFTER TEST.
DURABILITY: 10000 CYCLES

3. ELECTRICAL:
CURRENT: 3A FOR VBUS;
1.25A FOR GND PIN.
0.25A FOR OTHER

VOLTAGE: 20 V MAX
WITHSTANDING VOLTAGE: 100V AC R.M.S.
CONTACT RESISTANCE: 40mΩ MAX.
INSULATION RESISTANCE: 100MΩ MIN.

4. ENVIRONMENTAL
TEMPERATURE RANGE -25°C ~ +85°C

5. 尺寸标注事项: 若为首样全检, 重点管控尺寸, 图示有标注

6. 产品符合RoHS标准

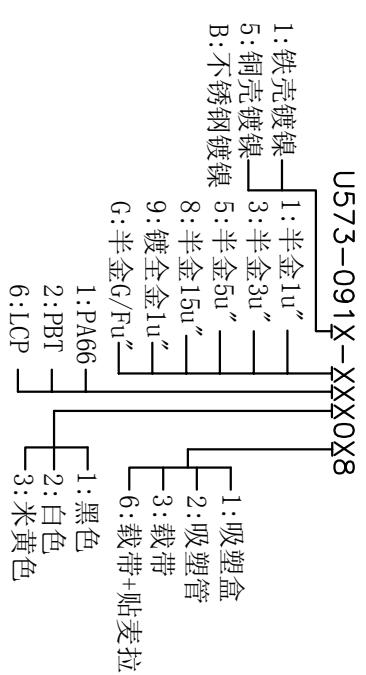
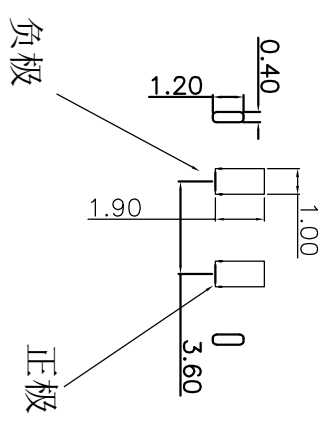
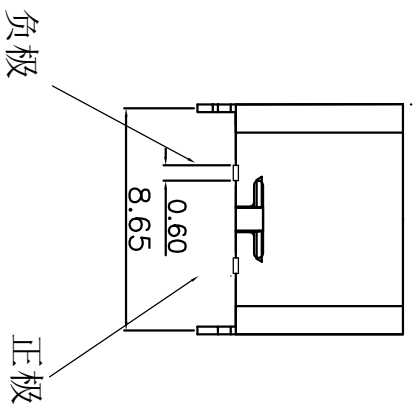
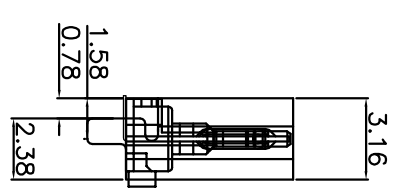
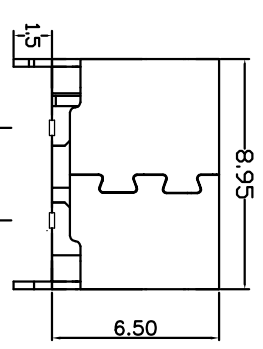

TOLERANCE UNLESS OTHERWISE SPECIFIED		HUA LIAN WEI TECHNOLOGY ELECTRONICS CO.,LTD.	
XXX ±0.10	X' ±3	HLW 深圳市华联威电子科技有限公司 HUA LIAN WEI TECHNOLOGY ELECTRONICS CO.,LTD.	
XX ±0.20	.XX ±2		
X ±0.30	.X ±2	PART NAME: TYPE C 2PIN 立贴高度6.5	
APPROVED		PART NO:	U573-091B-G61018
CHECKED		PROJECTION:	
DRAWN	weihong	UNIT:	mm
DATE	2021.11.06	SCALE	1:1
		SHEET	10F1
		REV.	A