

REV.	ECN.NO.	APPD.
AO	/	/

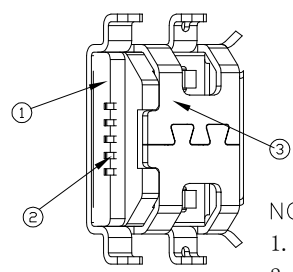
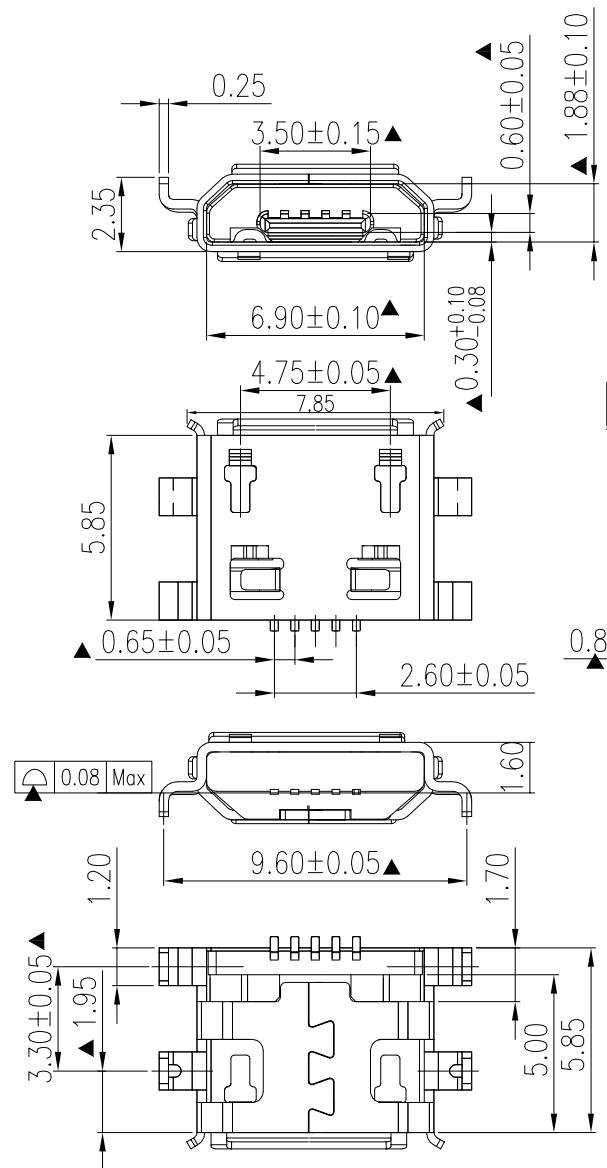

NOTES:

1. 成品功能要求面不可有端子压伤及塑胶毛边。
2. 标有“▲”记号者为重点检验尺寸。
3. 未标注尺寸公差为依自由公差为准。
4. 成品端子平面度必须100%检测▲。
5. 接缝强度1.0KgMin

规格说明 Specifications:  
电气特性 Electrical:

1. 额定电流: Current Rating  
1.8A/contact terminal
2. 额定电压: Voltage Rating  
30V DC
3. 接触阻抗 Contact Resistance  
50 milliohms MAX
4. 耐电压 Dielectric Withstanding Voltage:  
300 V AC AT Sea Level
5. 绝缘阻抗 Insulation Resistance:  
100MEGA ohms MIN

物理性能 Mechanical:

1. 插拔力: Connector Mate and Unmate Force  
Mate force: 3.0kgf (MAX)  
Unmate force: 0.7kgf (MIN)
2. 机械寿命: 5000次

原材料 Material:

1. 塑胶 Housing:  
High Temperature Thermoplastics,  
UL 94V-0 LCP Black
2. 端子 磷铜 C5191 EH
3. 外壳 Shell: H65 EH

电镀 Finish:

1. 端子 Contact: Plated Gold in Mating Area;  
Tin On Solder Tails
2. 外壳 Shell:  
Nickel Plating (能过炉自动上锡)

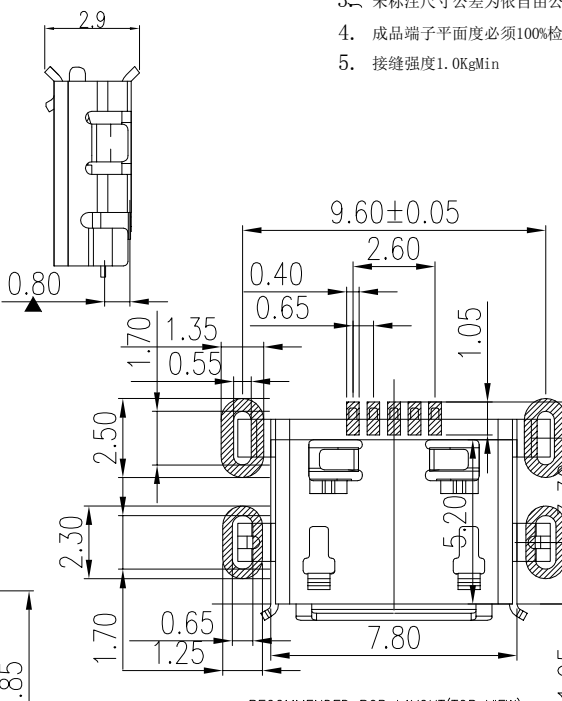

RECOMMENDED PCB LAYOUT (TOP VIEW)  
GENERAL TOLERANCES: ±0.05

U448-103X-XXXOX8

- 1: 铁壳镀镍
- 5: 铜壳镀镍
- 4: 铁壳镀金
- 6: 铜壳镀锡
- 1: 半金1u"
- 3: 半金3u"
- G: 半金G/Fu"
- 1: 吸塑盒
- 3: 冷封载带
- 8: 热封载带
- 1: 黑色
- 3: 米黄色
- 1: PA66
- 2: PBT
- 6: LCP

TOLERANCE UNLESS OTHERWISE SPECIFIED	
.XXX ±0.10	.X' ±3'
.XX ±0.20	.XX' ±2'
.X ±0.30	

**FLW** 深圳市华联威电子科技有限公司  
HUA LIAN WEI TECHNOLOGY ELECTRONICS CO;LTD.

APPROVED		PART NAME:	MICRO 5P/F B型插脚沉板0.8 H款			
CHECKED		PART No:	U448-1036-X21038		C	
DRAWN	weihong	PROJECTION:	UNIT:	SCALE:	SHEET:	REV.
DATE	2021.07.29		mm	1:1	10F1	AO