

| REV. | ECH. NO. | APPD. |
|------|----------|-------|
| A | / | / |

NOTES:

- MATERIAL:
 - WELDING: LCP UL94 V-0
 - CONTACT: COPPER ALLOY.
 - GOLD PLATED Min ON CONTACT AREA, 100u" Min TIN (LEAD FREE) ON SOLDER AREA, SHELL: SUS304-H, T=0.30±0.03mm 50u" NICKEL PLATING OVER ALL.
- MECHANICAL:
 - INSERTION: 5~20N.
 - EXTRACTION: 8~20N AFTER TEST.
 - DURABILITY: 5000 CYCLES
- ELECTRICAL:
 - CURRENT: 3A FOR VBUS; 1.25A FOR GND PIN.
 - 0.25A FOR OTHER.**
 - VOLTAGE: 20 V MAX
 - WITHSTANDING VOLTAGE: 100V AC R.M.S.
 - CONTACT RESISTANCE: 40mΩ MAX.
 - INSULATION RESISTANCE: 100MΩ MIN.
- ENVIRONMENTAL
 - TEMPERATURE RANGE -25°C ~ +85°C

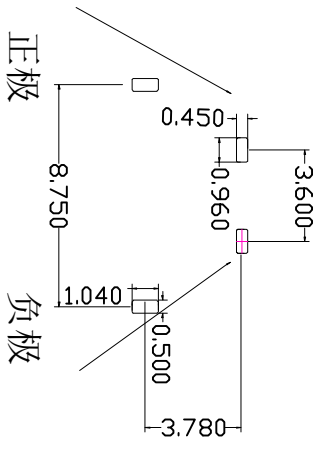
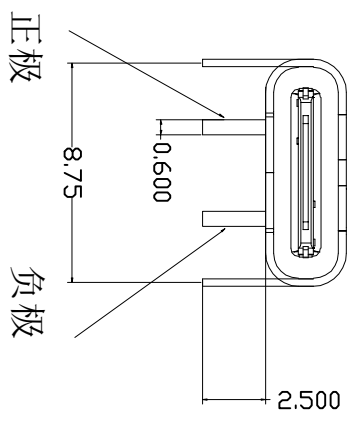
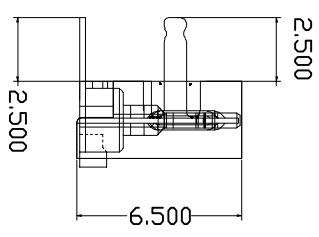
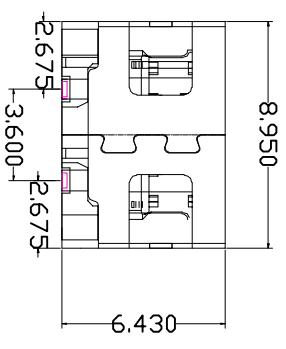

- U573-301X-XXX0X8**
- 1: 铁壳镀镍
 - 5: 铜壳镀镍
 - B: 不锈钢镀镍
 - 1: 半金1u"
 - 3: 半金3u"
 - 5: 半金5u"
 - 8: 半金15u"
 - 9: 镀全金1u"
 - G: 半金G/Fu"
 - 1: PA66
 - 2: PBT
 - 6: LCP
 - 1: 吸塑盒
 - 2: 吸塑管
 - 3: 裁带
 - 6: 裁带+贴麦拉
 - 1: 黑色
 - 2: 白色
 - 3: 米黄色

| TOLERANCE UNLESS OTHERWISE SPECIFIED | | HUA LIAN WEI 深圳市华联威电子科技有限公司 | |
|--------------------------------------|------------|--|------------------|
| XXX ±0.10 | X' ±3 | HUA LIAN WEI TECHNOLOGY ELECTRONICS CO.,LTD. | |
| XX ±0.20 | X' ±2 | | |
| X ±0.30 | X' ±2 | PART NAME: TYPE C 2P 90度两脚加长板 | |
| APPROVED | | PART NO: | U573-301B-X61018 |
| CHECKED | | PROJECTION: | |
| DRAWN | Qinyuhua | UNIT: | mm |
| DATE | 2021.11.06 | SCALE | 1:1 |
| | | SHEET | 10F1 |
| | | REV. | A |