

REV.	ECN. NO.	APPD.
A	EXXXXXXXXXX	Qinyuhua

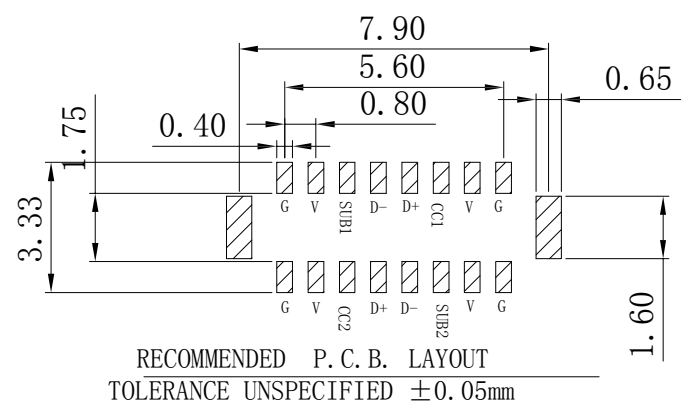

NOTES:

- 1.MATERIAL:
- 1.1 Housing:thermoplastic plastics
 - 1.2 terminals:Copper Alloy
Gold plated in contact area:
Tin plated in termination
Nickel Plated overall
 - 1.3 Shell:Steel&Copper Alloy
Nickel/Au Plated overall
- 2.characteristics:
- 2.1 Rating Voltage : 30V AC.
 - 2.2 Rating Current:
5A for Vbus PIN;1.25A for Vconn PIN
 - 2.3 Contact Resistance:40 mΩ MAX.
 - 2.4 Insulation Resistance:100 MΩ MIN.
 - 2.5 Withstanding Voltage:AC 100V
 - 2.6 Mating force: 5~20N MAX
 - 2.7 Extraction force:8~20N Min
 - 2.8 Life test:10000Cycles MIN.
 - 2.9 Temperature Range: -30℃~+80℃.
- The product must be compliance ROHS

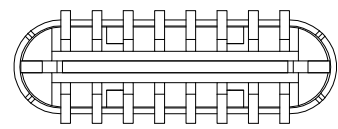
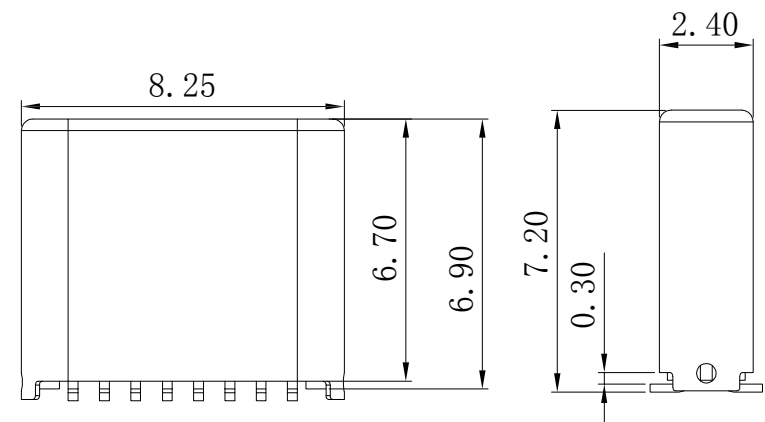

U512-014B-G61018

B: 不锈钢镀镍
G: 半金/Fu”

1: 吸塑盒
1: 黑色
6: LCP

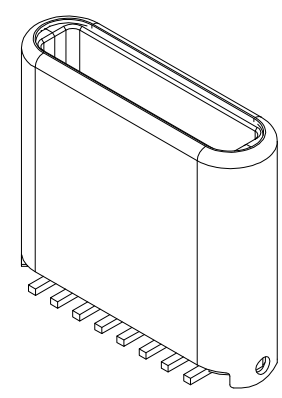
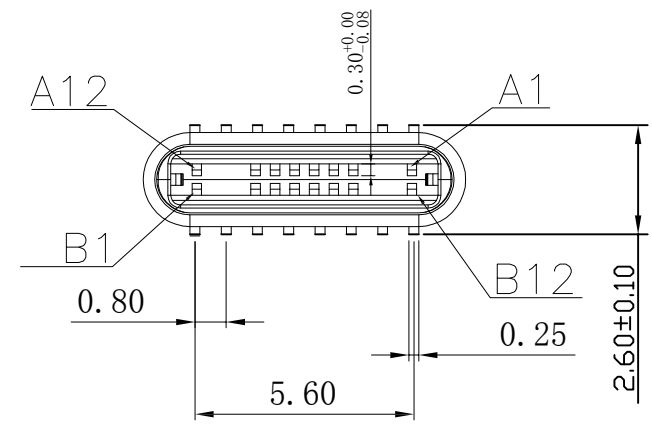

TOLERANCE UNLESS OTHERWISE SPECIFIED		FLW 深圳市华联威电子科技有限公司 HUA LIAN WEI TECHNOLOGY ELECTRONICS CO;LTD.						
.XXX ±0.10	.X° ±3°	APPROVED	PART NAME:	TYPE C 16P SMT 公头 铆合 7.2 短款				
.XX ±0.20	.XX° ±2°	CHECKED	PART No:	U512-014B-G61018			C	
.X ±0.30		DRAWN	chenyiting	PROJECTION:	UNIT:	SCALE	SHEET	REV.
		DATE	2022. 10. 09		mm	1:1	10F1	A