

承 认 书

Approval Sheet

客户 (Customer): /

客户料号 (Cus .P/N): /

华联威料号 (HLW P/N): FP4101-01268

品名规格 (PronameSpec): FPC 2.0间距0.5翻盖30PIN

送样日期 (Delivery Date): 2022/03/14

承认日期 (Acknowledge Date): 2022/03/14

Approved No:		客 户 Customer	
采 购 部 Purchasing Dept	品 质 部 QC Dept	工 程 部 Engineering Dept	确 认 Approved By
深 圳 市 华 联 威 电 子 科 技 有 限 公 司 SHEN ZHEN SHI HUA LIAN WEI ELECTRONICS TECHNOLOGY CO; LTD.			
业 务 部 Sales Dept	品 管 部 QC Dept	工 程 部 Engineering Dept	核 准 Checked By
万金菊	欠必锋	魏红	唐竹君

地址: 深圳市龙华区观澜街道桂香社区观澜桂花路 307 号

TEL: 0755-28888886 28888866

hua@hlwconn.com

[Http://www.hlwconn.com](http://www.hlwconn.com)

目 录

Contents

图纸.....	Page-03
产品规格书.....	Page04-05
产品检测报告.....	Page06-07
尺寸测试报告.....	Page08
电镀报告.....	Page09
盐雾报告.....	Page10
材质证明.....	Page11-12
SGS.....	Page13-46

REV.	ECN.NO.	APPD.
A	/	/

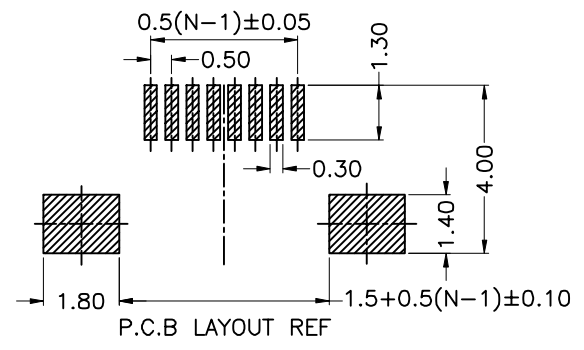
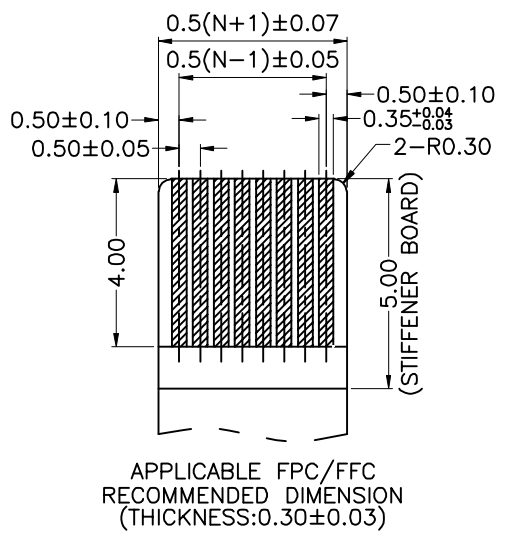
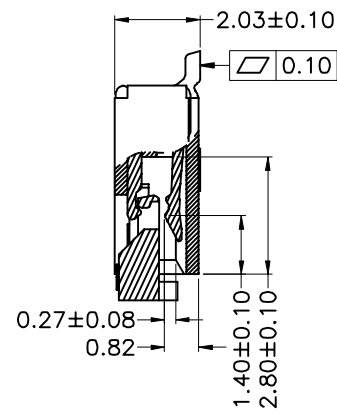
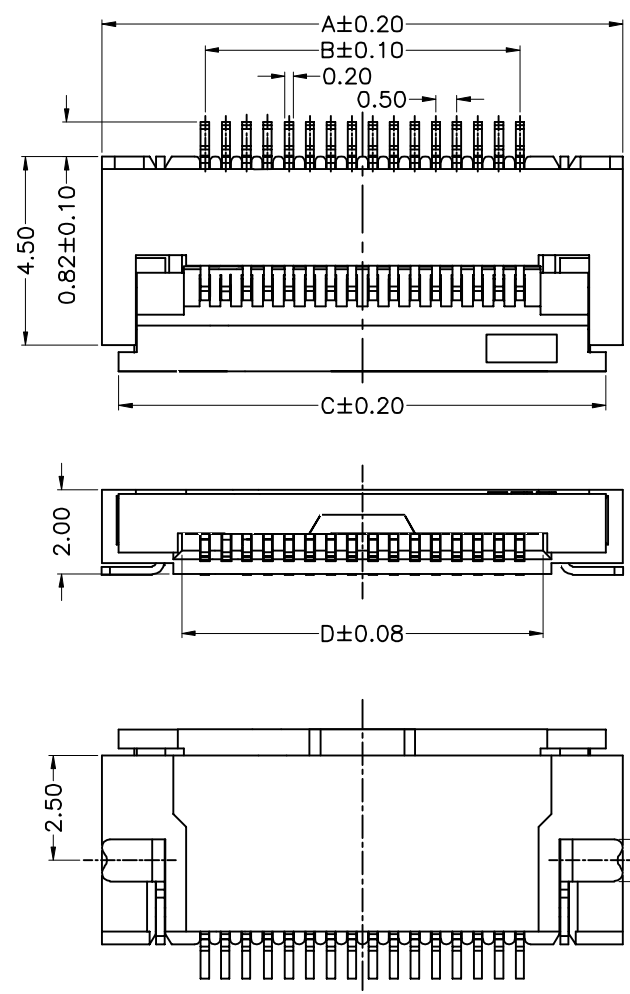

50	29.40	24.50	28.50	25.60
49	28.90	24.00	28.00	25.10
48	28.40	23.50	27.50	24.60
47	27.90	23.00	27.00	24.10
46	27.40	22.50	26.50	23.60
45	26.90	22.00	26.00	23.10
44	26.40	21.50	25.50	22.60
43	25.90	21.00	25.00	22.10
42	25.40	20.50	24.50	21.60
41	24.90	20.00	24.00	21.10
40	24.40	19.50	23.50	20.60
39	23.90	19.00	23.00	20.10
38	23.40	18.50	22.50	19.60
37	22.90	18.00	22.00	19.10
36	22.40	17.50	21.50	18.60
35	21.90	17.00	21.00	18.10
34	21.40	16.50	20.50	17.60
33	20.90	16.00	20.00	17.10
32	20.40	15.50	19.50	16.60
31	19.90	15.00	19.00	16.10
30	19.40	14.50	18.50	15.60
29	18.90	14.00	18.00	15.10
28	18.40	13.50	17.50	14.60
27	17.90	13.00	17.00	14.10
26	17.40	12.50	16.50	13.60
25	16.90	12.00	16.00	13.10
24	16.40	11.50	15.50	12.60
23	15.90	11.00	15.00	12.10
22	15.40	10.50	14.50	11.60
21	14.90	10.00	14.00	11.10
20	14.40	9.50	13.50	10.60
19	13.90	9.00	13.00	10.10
18	13.40	8.50	12.50	9.60
17	12.90	8.00	12.00	9.10
16	12.40	7.50	11.50	8.60
15	11.90	7.00	11.00	8.10
14	11.40	6.50	10.50	7.60
13	10.90	6.00	10.00	7.10
12	10.40	5.50	9.50	6.60
11	9.90	5.00	9.00	6.10
10	9.40	4.50	8.50	5.60
9	8.90	4.00	8.00	5.10
8	8.40	3.50	7.50	4.60
7	7.90	3.00	7.00	4.10
6	7.40	2.50	6.50	3.60
5	6.90	2.00	6.00	3.10
4	6.40	1.50	5.50	2.60
No. of Contacts	A	B	C	D
	Dimension			

- 1.MATERIAL:
- 1.1 HOUSING: LCP,UL94V-0; COLOR: NATURE.
 - 1.2 ACTUATOR: LCP,UL94V-0; COLOR: BLACK.
 - 1.3 CONTACT: C5191,T=0.20±0.01mm
 - 1.4 SOLDER PAD: C2680,T=0.20±0.01mm
- 2.FINISH:
- 2.1 CONTACT:100u" MIN. TIN PLATED IN SOLDER AREA 50u" MIN. NICKEL UNDERPLATED OVERALL.
 - 2.2 SOLDER PAD: 50u" MIN. NICKEL PLATED OVERALL. 100u" MIN. TIN PLATED OVERALL.

TOLERANCE UNLESS OTHERWISE SPECIFIED	
.XXX ±0.10	.X' ±3'
.XX ±0.20	.XX' ±2'
.X ±0.30	
APPROVED	
CHECKED	
DRAWN	weihong
DATE	2021.9.23

FLW 深圳市华联威电子科技有限公司
HUA LIAN WEI TECHNOLOGY ELECTRONICS CO;LTD.

PART NAME:	FPC 2.0间距0.5翻盖 30P				
PART No:	FP4101-01268				C
PROJECTION:	UNIT:	SCALE:	SHEET:	REV.	
	mm	1:1	10F1	A	

FPC系列產品SPEC

TEST ITEM		REQUIREMENT	PROCEDURE
1	Examination of Product	Meets requirements of product drawing. No physical damage.	Visual inspection.
2	Operating Temperature	-25°C ~+85°C	
3	Storage Temperature :	-25°C ~+85°C	
ELECTRICAL REQUIREMENT			
4	Rating Voltage	50V AC max	
5	Rating Current	0.5Amperes max	
6	Contact Resistance	[40]Milliohms Max.(Initial) [60]Milliohms Max.(Final)	Subject mated contacts assembled in housing to 40mV Max open circuit at 1A Max.
7	Dielectric withstanding Voltage	No creeping discharge or flashover shall occur.Current leakage: 0.5mA Max.	200V AC for 1minute Test between adjacent circuits of unmated connector.
8	Insulation Resistance	500M Ohm Min	Impressed voltage 200 VDC.Test between adjacent circuits of unmated connector.
Mechanical Requirement			
9	Connector Withdrawal Force	F(N)= P x 0.39 MIN (P: Number of Contacts) (With Black Slider) F(N)= P x 0.27 MIN (P: Number of Contacts) (With Brown Slider)	Operation Speed: 25mm/min.Measure the force required to mate connector.
10	Terminal & Solder Peg Retention Force	Test method complies with EIA-364-29	200gf MIN
11	Durability	See Note	Operation Speed : 200cycle/Hour.Durability Cycles : 20Cycles
12	Vibration	No electrical discontinuity greater than 1 μ sec shall occur.	Measure change in contact resistance after 2 hours of vibration in reach of the X,Y and Z directions. Frequency varying in 1 Minutes sweeping as 10~55~10 Hz with 1.5mm
13	Thermal Shock	5 Cycles - 55°C \pm 3°C for 30 minutes. +85°C \pm 2°C The connectors under test must be mated. There shall be no evidence of damage.	It shall be subjected to temperature cycle at the following condition 1 cycle consists of - 55°C \pm 3°C for 30 minutes. +85°C \pm 2°C for 30minutes . Time of cycles: 5 cycles. Test method complies with EIA-364-32
ENVIRONMENTAL REQUIREMENTS			
14	Solder ability	Wet solder coverage:95%Min	Solder Temperature : 260 \pm 5°C, Duration:5 \pm 0.5sec.
15	Resistance to Wave Soldering Heat	No physical damage shall occur.	Solder Temp. : 260 \pm 5°C, 10 \pm 1sec.

16	Salt spray test	Visual Inspection-No physical damageLLCR-60 mΩ max per contact	Mated connector expose to 5% salt concentration for 48 hours at temperature 35±2 °C .After the test specimens shall be washed with running water and dried naturally
----	-----------------	--	--

Product Qualification and Requalification test										
Test or Examination	Test Group									
	A	B	C	D	E	F	G	H	I	J
	Test Sequence (a)									
Examination of Product	1, 7	1, 9	1, 6	1, 5	1, 5	1, 5	1, 5	1, 3	1, 3	1, 3
Contact Resistance		2, 8	2, 5	2, 4	2, 4	2, 4	2, 4			
Dielectric withstanding	3, 6									
Insulation Resistance	2, 5									
Temperature Rising								2		
Mating Force		3, 7								
Unmating Force		4, 6								
Durability		5								
Vibration			3							
Mechanical Shock			4							
Solderability										2
Resistance to Soldering									2	
Thermal Shock				3						
Humidity Temperature	4				3					
Temperature Life						3				
Salt Spray							3			
備注	無客戶指定增加測試項目外，依照此標準進行產品可靠性評估。									

核准：唐竹君

制作人：魏紅

7	耐久性	测试速度：每分钟15个循环，测试次数：100次循环最少	插拔力計	不得发生物理损坏。	OK	OK	OK	OK	OK	V	
---	-----	-----------------------------	------	-----------	----	----	----	----	----	---	--

三. 环境特性测试 ENVIRONMENTAL TEST

序號 NO	測試項目 Testing Item	測試條件 Testing Conditions	測試設備 Testing Equipment	規格 SPEC	測試記錄Testing Result					判定 Judge	
					1	2	3	4	5	OK	NG
9	冷热冲击	温度-40±3℃ 温度105±3℃ 持续时间0.5H	高低温试验箱	不得发生物理损坏。	OK	OK	OK	OK	OK	V	
10	湿温循环	温度85℃±5℃， 持续时间:250H	湿温循环机	最大接触阻抗20mΩ	OK	OK	OK	OK	OK	V	
11	盐雾试验	温度:35±2℃ 12小时	盐雾试验箱	最大接触阻抗20mΩ	OK	OK	OK	OK	OK	V	
12	可焊性	焊锡温度: 260±5℃	熔锡炉	沾锡面积达90%以上	OK	OK	OK	OK	OK	V	
13	焊接耐热试验	260±5℃ 10秒	工业烘烤箱	不得发生物理损坏	OK	OK	OK	OK	OK	V	

綜合判定 TEST JUDGMENT	<input checked="" type="checkbox"/> 合格 (Acceptable) <input type="checkbox"/> 不合格 (Reject)										
-----------------------	---	--	--	--	--	--	--	--	--	--	--

核准(Approver): 欠必鋒 測試(Tester): 但芬



深圳市华联威电子科技有限公司

檢驗報告

首件檢驗
 入庫檢驗
 出貨檢驗
 客退檢驗
 退料檢驗
 其他
 2022年03月14日 版次:A1

料號	FP4101-01268	制令單號	/					送檢單位	工程部	首件製作者	裝配			
品名	FPC 2.0间距0.5翻盖 30PIN	客戶代號	/					批 量	/	送檢時間	/			
								數 量	5PCS	確認時間	/			
抽樣標準		<input checked="" type="checkbox"/> 單次 <input type="checkbox"/> 雙次					抽樣數	AQL	CRI:0	MAJ:0.4	MIN:0.6			
MIL-STD-105E(II)		<input checked="" type="checkbox"/> 正常 <input type="checkbox"/> 加嚴 <input type="checkbox"/> 減量					(5PCS)	ACC/RE.	0	/	/			
不良數:		CRI (/)		MAJ (/)		MIN (/)		不良率(%)		/				
NO.	檢驗項目 單位:MM/G	檢測 儀器	檢 驗 記 錄					品管判定		CRI	MAJ	MIN	備注	
			1	2	3	4	5	AC	RE					
	19.40±0.20	D	19.42	19.43	19.45	19.45	19.46	√						
尺 寸 測 量	14.50±0.10	D	14.52	14.53	14.54	14.55	14.56	√						
	0.82±0.10	D	0.85	0.84	0.83	0.81	0.82	√						
	18.50±0.20	D	18.52	18.53	18.52	18.53	18.56	√						
	15.60±0.08	D	15.63	15.65	15.67	15.63	15.65	√						
	2.50±0.20	D	2.52	2.53	2.54	2.56	2.52	√						
	1.00±0.20	D	1.02	1.03	1.01	1.03	1.04	√						
檢驗依據: <input checked="" type="checkbox"/> 《工程圖紙》 <input type="checkbox"/> 《檢驗規範》 <input type="checkbox"/> 《承認書》 <input type="checkbox"/> 樣品 <input type="checkbox"/> 其它														
檢測儀器:A游標卡尺 B千分尺 C厚薄儀 D投影鏡 E放大鏡 F顯微鏡 G錫爐 H插拔力器 I間位尺 J其它														
品保判定:		<input checked="" type="checkbox"/> 合格Accept <input type="checkbox"/> 退貨Reject <input type="checkbox"/> 特采Waive <input type="checkbox"/> 挑選Sort												

核准: 欠必鋒

審核: 李娟

檢驗員: 但芬

品名:FPC 2.0间距0.5翻盖30PIN 端子		版次:A.0																														
电镀规格:Ni40u", Sn40u"	日期:2021/12/12	页次:1/1																														
厂商:同华																																
测试设备:CMI X-射线膜厚测试仪																																
1、底层电镀测试 (Ni)																																
<table border="1"><thead><tr><th>数据</th><th>测试标准</th><th>实测值</th><th>判定</th><th>测试日期</th><th>测试时间</th></tr></thead><tbody><tr><td>1</td><td>40u"MIN</td><td>46.5u"</td><td>OK</td><td>2021/12/12</td><td>10:20:15</td></tr><tr><td>2</td><td>40u"MIN</td><td>48.3u"</td><td>OK</td><td>2021/12/12</td><td>10:20:17</td></tr><tr><td>3</td><td>40u"MIN</td><td>47.5u"</td><td>OK</td><td>2021/12/12</td><td>10:20:19</td></tr><tr><td>4</td><td>40u"MIN</td><td>42.4u"</td><td>OK</td><td>2021/12/12</td><td>10:20:21</td></tr></tbody></table>			数据	测试标准	实测值	判定	测试日期	测试时间	1	40u"MIN	46.5u"	OK	2021/12/12	10:20:15	2	40u"MIN	48.3u"	OK	2021/12/12	10:20:17	3	40u"MIN	47.5u"	OK	2021/12/12	10:20:19	4	40u"MIN	42.4u"	OK	2021/12/12	10:20:21
数据	测试标准	实测值	判定	测试日期	测试时间																											
1	40u"MIN	46.5u"	OK	2021/12/12	10:20:15																											
2	40u"MIN	48.3u"	OK	2021/12/12	10:20:17																											
3	40u"MIN	47.5u"	OK	2021/12/12	10:20:19																											
4	40u"MIN	42.4u"	OK	2021/12/12	10:20:21																											
2、表层电镀测试 (Sn)																																
<table border="1"><thead><tr><th>数据</th><th>测试标准</th><th>实测值</th><th>判定</th><th>测试日期</th><th>测试时间</th></tr></thead><tbody><tr><td>1</td><td>40u"MIN</td><td>45.3u"</td><td>OK</td><td>2021/12/12</td><td>10:25:10</td></tr><tr><td>2</td><td>40u"MIN</td><td>46.7u"</td><td>OK</td><td>2021/12/12</td><td>10:25:12</td></tr><tr><td>3</td><td>40u"MIN</td><td>48.9u"</td><td>OK</td><td>2021/12/12</td><td>10:25:14</td></tr><tr><td>4</td><td>40u"MIN</td><td>42.4u"</td><td>OK</td><td>2021/12/12</td><td>10:25:16</td></tr></tbody></table>			数据	测试标准	实测值	判定	测试日期	测试时间	1	40u"MIN	45.3u"	OK	2021/12/12	10:25:10	2	40u"MIN	46.7u"	OK	2021/12/12	10:25:12	3	40u"MIN	48.9u"	OK	2021/12/12	10:25:14	4	40u"MIN	42.4u"	OK	2021/12/12	10:25:16
数据	测试标准	实测值	判定	测试日期	测试时间																											
1	40u"MIN	45.3u"	OK	2021/12/12	10:25:10																											
2	40u"MIN	46.7u"	OK	2021/12/12	10:25:12																											
3	40u"MIN	48.9u"	OK	2021/12/12	10:25:14																											
4	40u"MIN	42.4u"	OK	2021/12/12	10:25:16																											

核准: 欠必锋

审核: 李娟

检验员: 但芬

盐水喷雾实验报告

试验方法	盐水喷雾腐蚀试验法	参考资料	MIL-STD-1216
METHOD	NEUTRL SALT SPRAY CORROSION TEST	REF	
客户	/	试验起始日期	2022年03月13日 20:00 时起
		DATE	2022年03月14日 08:00 时止
样品名称	FPC 2.0间距翻盖30PIN	试验数量	5PCS
P/N	FP4101-01268		

试验条件 (TEST CONDITION)

- 1、盐水溶解 (SALT SOLUTION: 浓度 $50 \pm 10\text{g/L}$, PH值6.5-7.2).
- 2、试验室温度 (TEMP. IT THE SPRAY DHAMBR): $35 \pm 1^\circ\text{C}$.
- 3、盐水桶温度 (TEMP. OF SALE SOL' N TANK): $35 \pm 1^\circ\text{C}$.
- 4、压力桶温度 (TEMP. OF SAR SUPPLIERY): $47 \pm 1^\circ\text{C}$.
- 5、试验室相对湿度 (R. H IN THE CHAMBER) 85%.
- 6、压缩空气压力 (COMPRESSED AIR PRESSURE): $1.00 \pm 0.01\text{Kg/cm}^2$.
- 7、样品放置位置 (SPECIMEN SUPPORTED ANGLE): 尼龙绳吊挂 $70^\circ - 90^\circ$.
- 8、喷雾收集量 (COLLECT RATE OF SALT SOL' N) $1-2\text{mL}/(8 \text{ cm}^2\text{hr})$.
- 9、盐雾测试时间: 12小时 (H)

判定方法 (ADFUSGD METHOD)

试验后以20倍放大镜观察、无蓝、绿色腐蚀物之现象 (不包含折弯处), 即判定合格. (Inspext the ecimen at 20 xmagnification no blue or green corrosion products are acceptable)

样品序号	试验后现象	判定
	PHENOMENON AFTER TEST	COMMENT
1	无蓝、绿色腐蚀物之现象	OK
2	无蓝、绿色腐蚀物之现象	OK
3	无蓝、绿色腐蚀物之现象	OK
4	无蓝、绿色腐蚀物之现象	OK
5	无蓝、绿色腐蚀物之现象	OK

核准: 欠必锋

审核: 李娟

试验员: 但芬

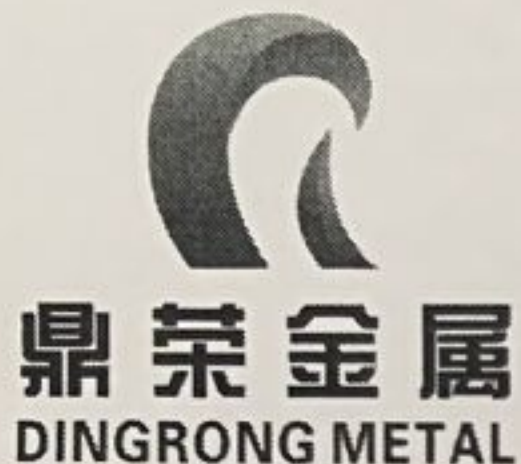

东莞市鼎荣金属材料有限公司

DongGuanDingRongMetalsMaterialCo., Ltd

产品质量证明书

CERTIFICATE OF QUALITY

电话: 0769-85220060

传真: 0769-85220061

网址: www.dingrongjinshu.com

邮箱: dingrong1978@163.com

地址: 东莞市虎门镇雅瑶怀雅大道73号

客户名称 Customer	华联威			产品名称 product name	C5191
合同编号 Contract No	P0202111130001			执行标准 Carried Standard	JISH3110:2012
尺寸公差 (mm) Size Tolerance	厚度 (Thickness)	0.3	+0-0.015	生产日期 Dete	2021-11-16
	宽度 (Width)	41/39	+0-0.08		

性能与含量

序号 NO.	批号 Lot No.	状态 Temper	卷数 Volume	规格及重量 Material Description			化学成份 Chemioal compositon							物理性能 Physical Property		
				厚度 Thick	宽度 Width	重量 Weight	铜 Cu%	锡 Sn%	磷 P%	锌 Zn%	铅 Pb%	铁 Fe%	镍 Ni%	抗拉强度 (N/mm ²) Tensile Strength	延伸率 (%) Elongation	硬度值 (HV) Hardness
1	F2555	EH	1	0.3	41	102.1	余量	5.0-7.0	0.03-0.35	≤0.20	≤0.020	≤0.10	-	635-720	≥5%	210-230
2	F2555	EH	5	0.3	39	489.7	余量	5.740	0.180	0.033	0.004	0.009	0.038	702	6	218
				合计 (Total)			591.8			质量检验章: Quality inspection stamp						

- 一、到货后请立即验收并放于室内干燥处。
- 二、本材质证明书希妥善保管, 如对我司产品品质与异议, 持材质证明在一个月內与我司联系, 我司将竭诚为您服务。
- 三、如有质量问题, 请注明产品牌号、规格、状态、批号、收获日期等信息, 以便于追溯与改进。
- 四、本材质证明涂改、复印无效。

品质主管: 范善益

审核人: 梅旭峰



东莞市海嵘兴塑胶有限公司

LCP材质分析报告

品 名	比 例	用 途
杜邦LCP树脂	0.68	构成材料主要成份
抗氧剂	0.003	抗氧化
日本住友TAP	0.002	润滑及增加流动性
大洋安定剂	0.005	稳定机械性能, 方便重复使用
玻纤	0.30	增强
色母	0.01	着色

注：以上数据真实可靠，但并非绝对值，并不做任何商业依据。

