

- SPECIFICATIONS:
1. ELECTRICAL CHARACTERISTICS:
- 1.1. RATING: 3A;
  - 1.2. CONTACT RESISTANCE: 30 mΩ MAX.(INITIAL);
  - 1.3. DIELECTRIC WITHSTANDING: 100V AC MIN.;
  - 1.4. INSULATION RESISTANCE: 100MΩ MIN.;
2. DURABILITY: 5,000 CYCLES MIN.;
3. INSERTION FORCE: 5-20N;
4. EXTRACTION FORCE: 6-20N;
5. WATER PROOFNESS: THIS PRODUCT IS BASED ON IPX7.
6. PLUG INTERFACE DIMENSIONS CONFORM TO USB2.0 SPEC.
7. PACKAGING: TAPE & REEL.

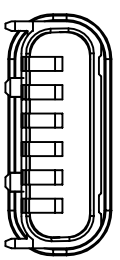

- U572-641X-XXXXX8
- 1: 铁壳镀镍
  - 5: 铜壳镀镍
  - B: 不锈钢镀镍
  - 1: 半金1u"
  - 3: 半金3u"
  - 5: 半金5u"
  - G: 半金G/Fu"
  - 9: 镀全金1u"
  - 4: 镀全亮锡
  - 1: PA66
  - 2: PBT
  - 9: PA10T
  - 1: 吸塑盒
  - 2: 吸塑管
  - 3: 载带
  - 6: 载带+贴麦拉
  - 1: 黑色
  - 2: 白色
  - 3: 米黄色

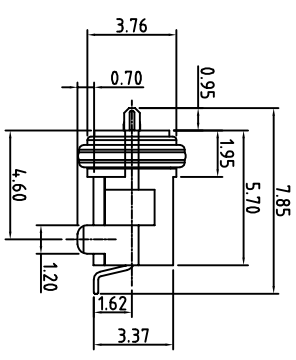
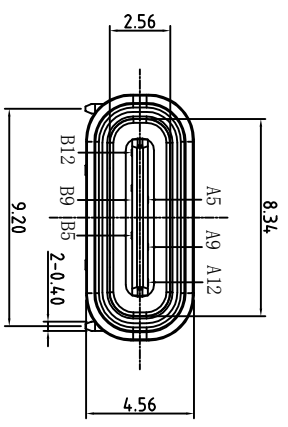
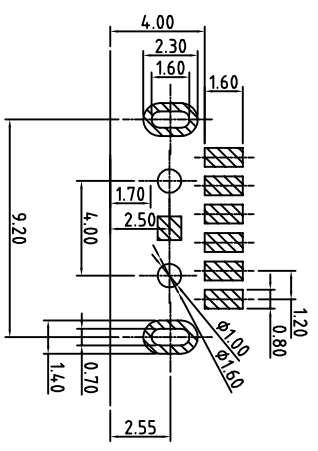
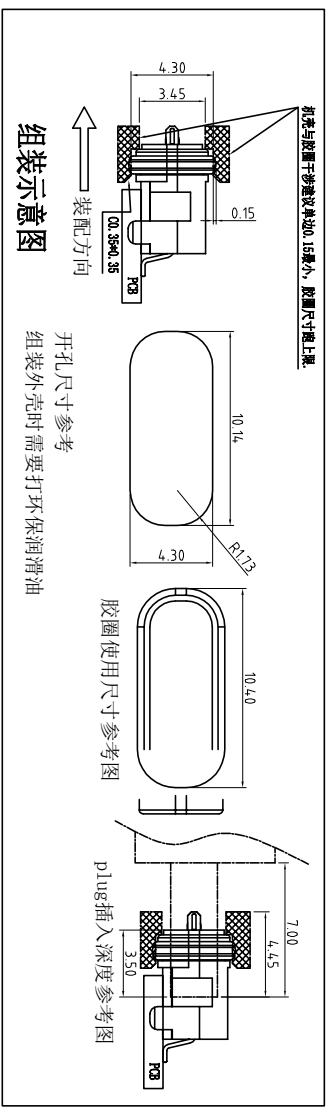
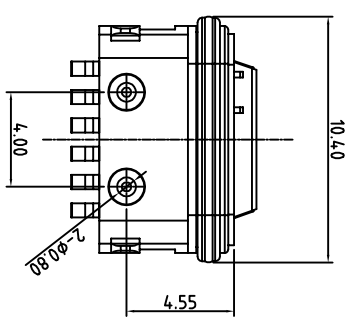

A5	CC1	B12	GND
A9	VBUS	B9	VBUS
A12	GND	B5	CC2
PIN	SIGNAL NAME	PIN	SIGNAL NAME
9		8	

TOLERANCE UNLESS OTHERWISE SPECIFIED		HUA LIAN WEI TECHNOLOGY ELECTRONICS CO.,LTD.	
XXX ±0.10	X' ±3	<b>HLW</b> 深圳市华联威电子科技有限公司	
XX ±0.20	.XX ±2	PART NAME: TYPE C 6P 拉伸款	
X ±0.30		PART No: U572-641B-C91038	
APPROVED		UNIT: mm	
CHECKED		SCALE: 1:1	
DRAWN	yongguifeng	SHEET: 1 OF 1	
DATE	2021.12.01	REV. A	