

| REV. | ECN.NO. | APPD. |
|------|-------------|------------|
| A | EXXXXXXXXXX | chenyiting |

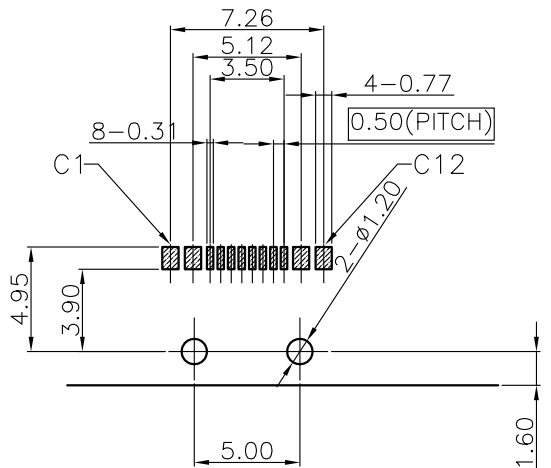

RECOMMENDED PCB LAYOUT(TOP VIEW)
THICKNESS T=1.0mm
DEFAULT TOLERANCE+/-0.05

- NOTES:
1.MATERIAL:
1.1 Housing:thermoplastic plastics
1.2 terminals:Copper Alloy
Gold plated in contact area:
Tin plated in termination
Nickel Plated overall
1.3 Shell:Steel&Copper Alloy
Nickel/Au Plated overall
2.characteristics:
2.1 Rating Voltage : 30V AC.
2.2 Rating Current:
5A for Vbus PIN;1.25A for Vconn PIN
2.3 Contact Resistance:40 mΩ MAX.
2.4 Insulation Resistance:100 MΩ MIN.
2.5 Withstanding Voltage:AC 100V
2.6 Mating force: 5~20N MAX
2.7 Extraction force:8~20N Min
2.8 Life test:10000Cycles MIN.
2.9 Temperature Range: -30℃~+80℃.
The product must be compliance ROHS

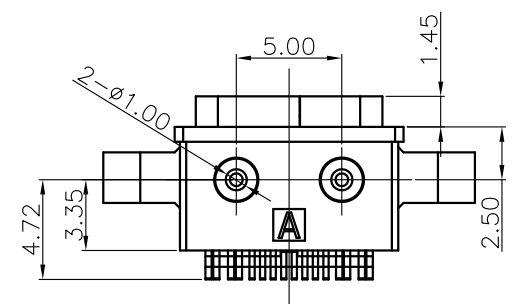
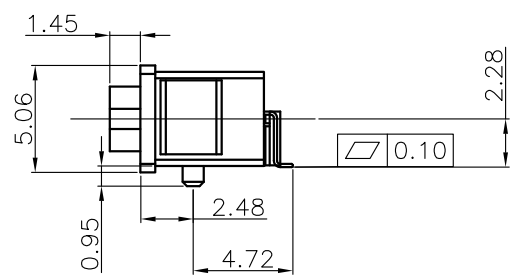
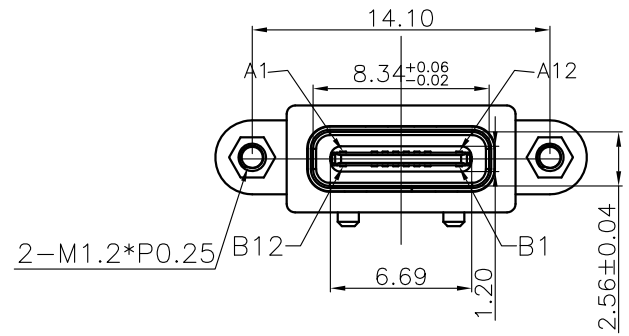
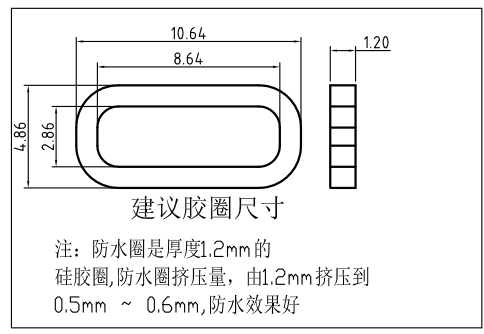
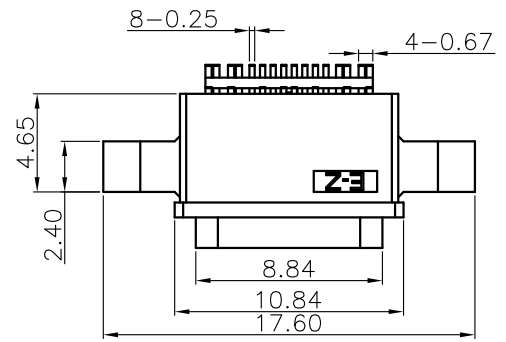
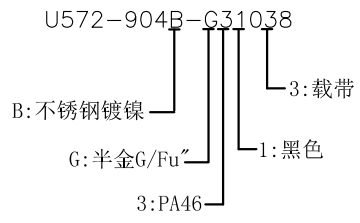

INTERFACE(FRONT VIEW)

| | | | | | | | | | | | |
|-----|-----|-----|------|------|-----|-----|------|------|-----|-----|-----|
| A1 | A2 | A3 | A4 | A5 | A6 | A7 | A8 | A9 | A10 | A11 | A12 |
| GND | | | VBUS | CC1 | DP1 | DN1 | SBU1 | VBUS | | | GND |
| GND | | | VBUS | SBU2 | DN2 | DP2 | CC2 | VBUS | | | GND |
| B12 | B11 | B10 | B9 | B8 | B7 | B6 | B5 | B4 | B3 | B2 | B1 |

PIN ASSIGNMENT

| | | | | | | | | | | | | |
|-------------|--------|-------|------|-----|-----|-----|-----|-----|------|-----|-------|--------|
| PIN NO. | A1&B12 | A4&B9 | B8 | A5 | B7 | A6 | A7 | B6 | A8 | B5 | A9&B4 | A12&B1 |
| SINGAL NAME | GND | VBUS | SBU2 | CC1 | DN2 | DP1 | DN1 | DP2 | SBU1 | CC2 | VBUS | GND |
| PCB PAD NO. | C1 | C2 | C3 | C4 | C5 | C6 | C7 | C8 | C9 | C10 | C11 | C12 |

| | | | | | |
|--------------------------------------|------------|---|---------------------|-------|--------|
| TOLERANCE UNLESS OTHERWISE SPECIFIED | | FLW 深圳市华联威电子科技有限公司 | | | |
| .XXX ±0.10 .XX ±0.20 .X ±0.30 | | HUA LIAN WEI TECHNOLOGY ELECTRONICS CO;LTD. | | | |
| APPROVED | | PART NAME: | TYPE C 16P SMT带螺母有柱 | | |
| CHECKED | | PART No: | U572-904B-G31038 | C | |
| DRAWN | chenyiting | PROJECTION: | UNIT: | SCALE | SHEET |
| DATE | 2023.06.30 | | mm | 1:1 | 1 OF 1 |
| | | | | REV. | A |

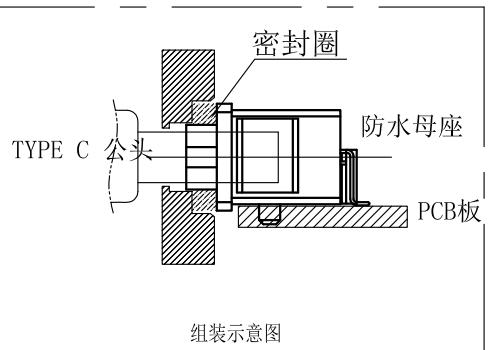

由 Autodesk 教育版产品制作

由 Autodesk 教育版产品制作